



ERSKINE

ATTACHMENTS, INC.

A Legacy of Excellence Since 1948

P.O. Box 1083 • Alexandria, MN 56308 • 866-458-8224

Hydraulic Earth Auger Attachment

Models: EA10, EA15, EA19

OPERATOR'S MANUAL

Serial Number _____

Model Number _____



WARNING! Avoid injury or death. Read and understand this entire manual before installing, operating or servicing this equipment.

TABLE OF CONTENTS

To The Owner	2
Safety Information	3 – 4
Skid Steer Loader Installation Instructions	5
Hydraulic Hookup Instructions	6
Operating Instructions	7
Maintenance Instructions	8
Troubleshooting	9
Drive Unit Models EA10, EA15, EA19 -Specifications	10
Drive Unit Models EA10, EA15, EA19 - Motor Exploded View	11
Drive Unit Models EA10, EA15, EA19 - Motor Parts List	12
Drive Unit Models EA10, EA15, EA19 - Motor Service Procedures	13 – 16
Planetary Exploded View & Parts List	17
Planetary Service Procedures	18
Accessories & Auger Replacement Wear Parts	19

***Congratulations on the purchase of your
Erskine Earth Auger Attachment.***

You have invested in a quality piece of equipment backed by people with years of experience. But only by proper installation, operation, and maintenance can you expect to receive the dependable performance and long life for which the earth auger was designed.

This operator's manual contains information regarding the installation, operation, safe use, and maintenance of your Erskine Hydraulic Earth Auger Attachment. ***Please be sure all operators study this manual carefully and keep it on file for future reference.***

After reading this manual, if you have any questions about your Erskine Earth Auger Attachment please contact us immediately as follows:

Toll Free: 866-458-8224

Fax: 320-759-1590

Erskine strives to provide superior products and the highest level of customer service. If you have any suggestions on how we can improve for the future, we would appreciate hearing from you.

Thank you for putting your trust in ERSKINE ATTACHMENTS.

ERSKINE ATTACHMENTS, INC.

P.O. Box 1083 • Alexandria, MN 56308

SAFETY INFORMATION

THE USE OF THIS EQUIPMENT IS SUBJECT TO CERTAIN HAZARDS WHICH CANNOT BE PROTECTED AGAINST MECHANICAL MEANS OR PRODUCT DESIGN. ALL OPERATORS OF THIS EQUIPMENT MUST READ AND UNDERSTAND THIS ENTIRE MANUAL, PAYING PARTICULAR ATTENTION TO SAFETY AND OPERATING INSTRUCTIONS, PRIOR TO USING THE EA AUGER. IF THERE IS SOMETHING IN THIS MANUAL YOU DO NOT UNDERSTAND, ASK YOUR SUPERVISOR TO EXPLAIN IT TO YOU. FAILURE TO OBSERVE THESE SAFETY PRECAUTIONS CAN RESULT IN DEATH OR SERIOUS INJURY OR SERIOUS EQUIPMENT DAMAGE.



All bystanders should be kept a minimum of 10 feet away from working area of the earth auger.



Always wear an OSHA approved hard hat and safety eye protection when operating or servicing this equipment. Do not wear loose fitting clothing, flopping cuffs, dangling neckties and scarves, or rings and wrist watches that can catch moving parts.



An operator must not use drugs or alcohol, which can alter his alertness or coordination. An operator taking prescription or over the counter drugs should seek medical advice on whether or not he can safely operate equipment.



Always locate underground electrical wires, telephone cables, and gas, water, and sewer lines before digging. Maintain safe clearance and avoid contact with any underground or overhead utility lines or electrically charged conductors.



Never alter or remove any safety decals or safety shields. Check this manual for location of these items and replace immediately if damaged or illegible.



Never adjust a relief valve for pressure higher than recommended by vehicle manufacturer.



Whenever changing or installing this or other attachments, make sure all connections are securely fastened.



Travel only with the earth auger in a safe transport position to prevent uncontrolled movement. Drive slowly over rough ground and on slopes. Tether earth auger with a chain, if necessary, to prevent uncontrolled swinging of earth auger when moving from hole to hole. Remove earth auger from vehicle when transporting to and from job site.



Before exiting the vehicle, lower earth auger to ground, turn off vehicle engine and lock vehicle breaks.

(continued)

SAFETY INFORMATION



Never check a pressurized system for leaks with your bare hand. Oil escaping from pinhole leaks under pressure can penetrate skin and could cause serious infection. Hold a piece of cardboard up next to suspected leaks and wear a face shield or safety eye protection. If any fluid is injected into the skin, it must be removed immediately by a doctor familiar with this type of injury.



Before disconnecting hydraulic lines or fittings be sure to relieve all pressure by cycling all hydraulic controls after shutdown. Remember hydraulic systems are under pressure whenever the engine is running and may hold pressure after shutdown. Before applying pressure to the system make sure all connections are tight and that there is no damage to lines, fittings, and hoses.



Flow and pressure gauges, fitting, and hoses must have a continuous operating pressure rating of at least 25% higher than highest pressures of the system.



Avoid steep hillside operation, which could cause the vehicle to overturn. Consult your vehicle operator's and safety manuals for the maximum incline allowable.



Never perform any work on an earth auger unless you are authorized and qualified to do so. Always read the operator service manual before any repair is made. After completing maintenance or repair, check for correct functioning of the earth auger. If not functioning properly always tag "DO NOT OPERATE" until all problems are corrected.



This manual covers the safe use, installation, operation, and service instructions for the earth auger only. Always read the operating and safety manuals prepared for your vehicle and any other attachments before using them.

SKID STEER LOADER INSTALLATION INSTRUCTIONS

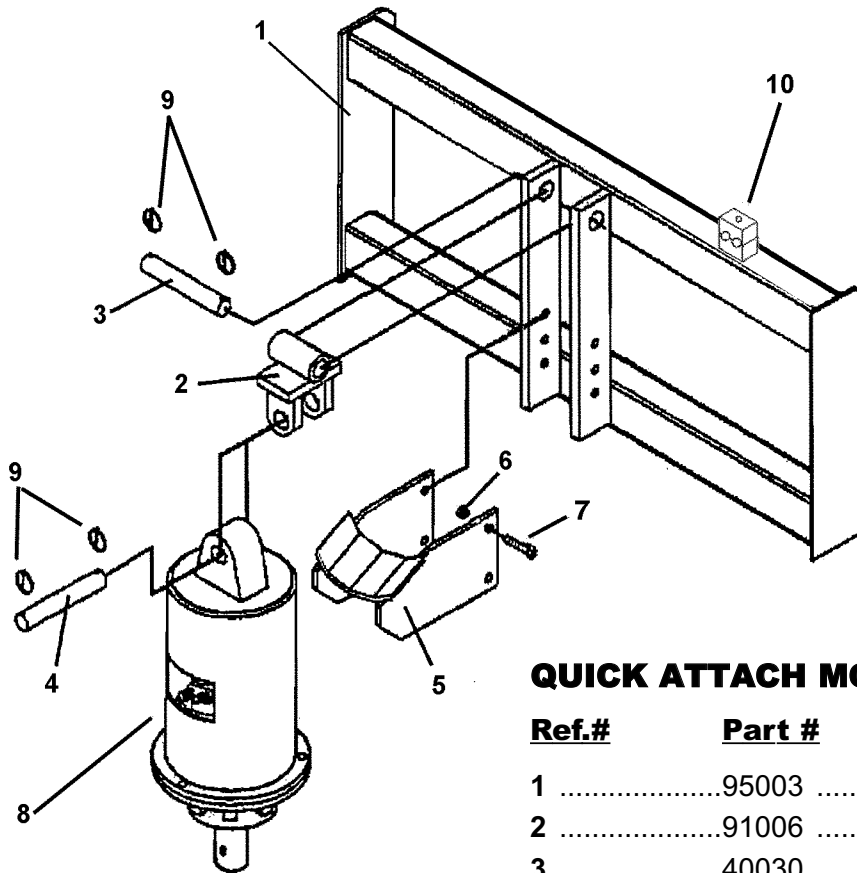

QUICK ATTACH MOUNTING BRACKET

<u>Ref.#</u>	<u>Part #</u>	<u>Description</u>
1	95003	Mount Weldment
2	91006	Knuckle Weldment
3	40030	Short Pin
4	40031	Long Pin
5	91011	Carrier Weldment
6	40005	1/2\"-13 Nut
7	40006	1/2\"-13 HHCS 2-1/4\" Long
8	N/A	Drive Unit
9	40009	Snap Pin
10	40018	Hose Holder

1. **READ AND UNDERSTAND ALL SAFETY INFORMATION BEFORE ATTEMPTING INSTALLATION.**
2. Remove bucket or other attachment from vehicle quick attach mechanism.
3. Assemble carrier weldment (5) to quick attach mounting bracket (1) with supplied 1/2\"-13 HHCS 2\" Long (7) and 1/2\"-13 (6) hex nut.
4. Attach quick attach mounting bracket (1) to vehicle quick attach mechanism as per vehicle manufacturer's recommendations.
5. Attach knuckle weldment (2) to the quick attach mounting bracket (1) with pin (3). Secure pin (3) with supplied snap clip (4).
6. Attach and secure drive unit (8) to knuckle weldment (2) with pin (3). Secure pin (3) with supplied snap clip (4).
7. Refer to the "Hydraulic System Hook-up" (page 11) in this manual for hydraulic connection instructions and recommendations.

HYDRAULIC SYSTEM HOOK-UP INSTRUCTIONS

1. Once the installation instructions are complete you are now ready to make the hydraulic connections necessary to operate your earth drill. **Read and understand safety information prior to making hydraulic connections.**
2. Your equipment dealer is in the best position to advise you as to where the best place on your machine is to make the hydraulic connections to power your earth drill drive unit. Some of the most common places to “tap” into the hydraulic system on various types of machines are as follows:

Skid Steer LoadersAuxiliary Hydraulic Outlets.

Backhoes & ExcavatorsAuxiliary Hydraulic Outlets or Bucket Curl Cylinder Outlet.

Wheel LoadersAuxiliary Hydraulic Outlets or Bucket Dump Cylinder Circuit.

3. Determine the length of hydraulic hoses required to plumb drive unit into the place on your machine where you will be “tapping” in to the hydraulics. Be sure the two hydraulic hoses are long enough to perform at the full range of the earth drills’ operating capacity.
4. Models EA10, EA15, and EA19 require two ½” I.D. hoses with #10 JIC female fittings on one end of each to connect hoses to drive unit fittings.
5. Once all hydraulic connections have been made and checked for leaks and proper hose lengths, you are now ready to operate your earth drill. **Read and understand operating instructions and safety information prior to operating your earth drill.**



WARNING! Hoses and Fittings must have a Continuous Operating Pressure Rating of at least 25% Higher than the Highest Pressures of the System that you are “tapping” into.

OPERATING INSTRUCTIONS

1. After all installation instructions have been completed, safety information read and understood and the rest of this operator's manual has been reviewed, your Hydraulic Earth Drill is now ready to use.
2. With the auger raised off the ground and the vehicle engine set at a low RPM, activate the earth drill control valve to determine position control valve lever must be in to turn auger in a forward (clockwise) rotation. This is the "digging" position.
3. Before beginning to dig, experiment with auger speed to determine a suitable auger RPM. Generally in light and sandy soil a high RPM is desirable. In hard, rocky, or frozen soils a slower RPM is desirable. To increase auger RPM, increase vehicle engine RPM. To decrease auger RPM, decrease vehicle engine RPM.
4. Return earth drill control valve to neutral position to stop the auger. Lower the auger to the ground so that only the center point penetrates the ground about 2".
5. Activate the earth control valve so auger is turning in a forward (clockwise) rotation. Use only enough down pressure to assure positive penetration of auger into the ground. Ease up on down pressure if auger rotation slows down drastically or stalls. Excessive down pressure will cause the auger to stall frequently.
6. When the auger has penetrated the ground about 24", raise the auger from the hole to clean the dirt out. Repeat this procedure until the desired hole depth is obtained.
7. Once the required hole depth is reached, allow the auger to turn a few seconds at this depth to clean the hole.
8. Return the earth drill control valve to the neutral position to stop the rotation of the auger. Raise the auger out of the hole, move away from the hole, then activate the earth drill control valve to spin the loose soil off of the augers.
9. If necessary, repeat steps 7 & 8 to obtain a cleaner hole.
10. In some soil conditions or when excessive down pressure is applied, auger may "screw" itself into the ground and become stuck causing earth drill to stall. If this happens, reverse the auger rotation (counter Clockwise) by moving the control valve lever to the reverse position and slowly raise the auger. Once the auger is unstuck, return the control valve lever to the forward position and continue digging.
11. If the auger becomes lodged under rocks, roots, or other large obstructions, do not attempt to raise auger out of the ground. See step 10 for proper procedure to relieve the auger.
12. Avoid excessive side loading to the earth drill which can cause drive unit or auger damage.
13. Keep auger teeth and points in good condition. Check frequently and always keep spares on hand so they can be replaced as wear is detected to avoid damage to tooth holders and auger flighting.

MAINTENANCE INSTRUCTIONS

1. **CLEAN HYDRAULIC OIL IS ESSENTIAL!** 80% of all hydraulic component failures are caused by contamination of the hydraulic oil. Always keep all dirt and other contaminants from entering hydraulic system during disconnect and connect operations. Always use dust caps and plugs on all quick disconnects when not in use. Tightly cap all hydraulic openings to hold oil in and keep dirt and other contaminants from entering hydraulic systems.
2. **CHECK ALL HYDRAULIC OIL DAILY FOR CONTAMINATION.** If contamination is present, determine the source of the problem.
3. **INSPECT ALL HYDRAULIC HOSE ASSEMBLIES DAILY** for cracked and brittle covers caused by excessive heat. Reduced viscosity of hydraulic oil occurs at higher operating temperatures and causes a breakdown of fluid additives such as wear inhibitors. Excessive heat will cause higher internal leakage in drive unit motor to become brittle and crack. Replacement of hoses before failure will prevent loss of hydraulic oil, time consuming “bleeding” of system, hydraulic oil contamination, and component damage caused by cavitations. It will also reduce the chance of personal injury caused by hydraulic fluid.
4. **CHECK AUGER DAILY** for loose, worn or broken cutting teeth and point. Worn teeth or point can drastically affect auger penetration and greatly reduce auger life expectancy. Always keep spare teeth and points on hand. Some digging conditions may require checking teeth and point at more frequent intervals.
5. **CHECK DRIVE UNIT AND ALL ACCESSORIES DAILY** for loose, bent, cracked, or worn, bolts and fasteners. Always use grade 5 or better replacement bolts. Always use lock washers with standard hex nuts or self locking nuts.
6. **CHECK ALL CONNECTING PINS DAILY** for bends, cracks, breaks, or wear. Replace if any of these conditions exist.
7. **CHECK DRIVE UNIT OUTPUT SHAFT DAILY** for bends, cracks, breaks, or wear. Replace if any of these conditions exist.
8. **CHANGE PLANETARY GEAR REDUCTION OIL AFTER FIRST 50 HOURS OF OPERATION, THEN EVERY 1000 HOURS OR IN ONE YEAR, WHICHEVER COMES FIRST.** Use mild extreme pressure lubricant API-GL-5 number 80 or 90 for filling planetary gear reduction under normal temperature ranges between 0 degrees and 120 degrees. Approximate oil capacity for models EA10, EA15PD, and EA19 is two pints. Check oil level daily to assure proper lubrication is maintained.
9. When storing Drive Unit for any length of time be sure Drive Unit motor and hoses are full of clean oil. Also, be sure that Planetary Gear Reduction is full to the recommended capacity for each model as outlined in number 8 above.
10. Drive Unit output shaft, inside of Auger Collar, Variable Auger Extension shaft, inside of Variable Auger Extension Collar and all Connecting Pins should be coated liberally with grease as required to prevent rust and reduce wear.
11. Once paint has been worn off auger, coat liberally with grease as required, to prevent rusting.
12. Check Planetary Gear oil as follows. Lie Drive Unit horizontal with ground, place bottom drain plug straight up. Remove plug, tilt drive unit at 2:00 or 10:00. Fill until oil leaks out from hole at one of these positions.

TROUBLESHOOTING

Problem	Possible Cause	Solution
Slow Speed	Low flow	Check Flow Meter. If low, investigate the cause.
	Line restrictions	Clear lines.
	Fittings or connections too small	Replace with proper sizes.
	Oil filter dirty	Replace.
	Hydraulic pump worn or damaged	See Dealer for repair.
Insufficient Digging Power	Worn Teeth Or Point	Replace.
	Low System Pressure	Check Pressure Gauge. If low, investigate cause.
	Relief Valve damaged or setting wrong	Adjust or replace as required.
	Excessive Load	Reduce load to within machine specifications.
Reverse Direction	Hoses Reversed	Re-install hoses correctly.
Excessive Oil Heating	Line Restrictions	Clear lines.
	Fluid Dirty	Replace hydraulic fluid & filter.
Oil Leaks	Insufficient amount of hydraulic fluid	Fill reservoir to proper level. Increase reservoir storage capacity.
	Hoses loose or damaged	Tighten or replace.
	Fittings loose or damaged	Tighten or replace.
	Hydraulic motor seals worn or damaged	See dealer for repair.

For further assistance, please call your dealer, or contact our sales department as follows:

Toll Free: 866-458-8224

Fax: 320-759-1590

DRIVE UNIT MODELS EA10, EA15, EA19

SPECIFICATIONS

MODEL EA10

Maximum Auger Diameter:24"
 Minimum Hydraulic Flow:06 gpm
 Maximum Hydraulic Flow:15 gpm
 Maximum Continuous Operating PSI:3750 psi
 Maximum Back Pressure:1500 psi

Output Speed		Output Torque	
GPM	RPM	PSI	LB/F
06	49	2000	955
08	51	2500	1194
10	64	3000	1433
12	77		
15	96		

MODEL EA15

Maximum Auger Diameter:30"
 Minimum Hydraulic Flow:10 gpm
 Maximum Hydraulic Flow:25 gpm
 Maximum Continuous Operating PSI:3750 psi
 Maximum Back Pressure:1500 psi

Output Speed		Output Torque	
GPM	RPM	PSI	LB/F
10	41	2000	1482
14	58	2500	1853
18	74	3000	2224
20	83		
25	104		

MODEL EA19

Maximum Auger Diameter:36"
 Minimum Hydraulic Flow:15 gpm
 Maximum Hydraulic Flow:30 gpm
 Maximum Continuous Operating PSI:3250 psi
 Maximum Back Pressure:1500 psi

Output Speed		Output Torque	
GPM	RPM	PSI	LB/F
15	49	2000	1861
20	66	2500	2326
24	79	3000	2791
28	92		
30	98		

Output speed and torque specifications are based on theoretical values and are provided for comparative purposes only. Erskine is continually striving to improve its products. Therefore, we reserve the right to make changes to our products or specifications at any time without notice or obligation.

MOTOR EXPLODED VIEW DRIVE UNIT MODELS EA10, EA15, EA19

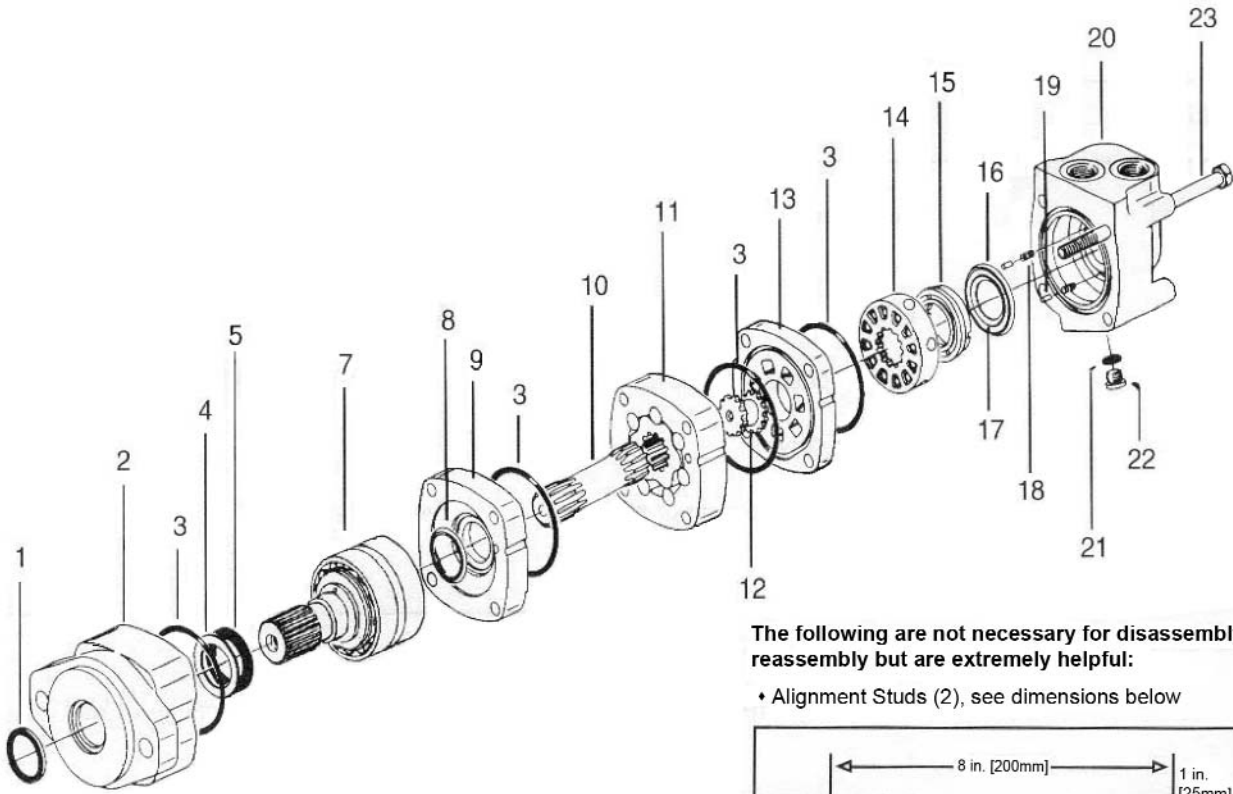

The following are not necessary for disassembly and reassembly but are extremely helpful:

- Alignment Studs (2), see dimensions below

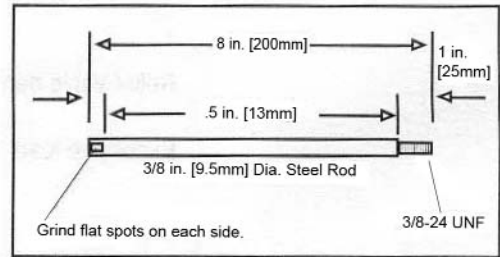

NOTE: Unless otherwise indicated, measurements are given in inches [mm] throughout the Hydraulic Motor Service Procedures.

MOTOR PARTS LIST DRIVE UNIT MODELS EA10, EA15, EA19

Ref.#	Part #	Description	Qty	Models Used On
1	62001	Dust Seal	1	All
2	62002	Bearing Housing	1	All
3	62003	Seal	4	All
4	62004	Back Up Washer	1	All
5	62005	Shaft Seal	1	All
7	62006	Bearing Shaft Assembly	1	All
8	62007	Shaft Face Seal	1	All
9	62008	Wear Plate	1	All
10	62009	Splined Drive	1	EA10
10	62010	Splined Drive	1	EA15
10	62011	Splined Drive	1	EA19
11	62013	Geroler	1	EA10
11	62014	Geroler	1	EA15
11	62015	Geroler	1	EA19
12	62017	Valve Drive	1	All
13	62018	Valve Plate	1	All
14	62019	Valve	1	All
15	62020	Balancing Ring	1	All
16	62021	Outer Face Seal	1	All
17	62022	Inner Face Seal	1	All
18	62021	Spring	2	All
19	62022	Pin	2	All
20	62023	Valve Housing	1	All
21	62024	Case Drain plug Seal	1	All
22	62025	Plug	1	All
23	62026	Tie Bolt	4	EA10
23	62027	Tie Bolt	4	EA15
23	62028	Tie Bolt	4	EA19
Not Shown	62030	Seal Kit	1	All

Tools Required For Disassembly & Reassembly:

- Torque Wrench 500 lb. in. Capacity
- 12-16 Breaker Bar
- 9/16" Socket
- Small Screwdriver 6-8 x 1/4" Blade
- 3/16" Allen Wrench
- Press
- Shaft Seal Installation Tool

MOTOR SERVICE PROCEDURES

DRIVE UNIT MODELS EA10, EA15, EA19

DISASSEMBLY:

Cleanliness is extremely important when repairing a hydraulic motor. Work in a clean area. Before disconnecting the lines, clean the port area of the motor thoroughly. Use a wire brush to remove foreign material and debris from and around the exterior joints of the motor. Check the shaft and keyslot and remove all nicks, burrs or sharp edges that might damage the bearing housing seals when installing the shaft and the bearing assembly. Before starting the disassembly procedures, drain the oil from inside the motor.

1. Place the motor in a vise with the output shaft down (Fig.1). Clamp across the mounting flange of the motor, not the housing. Excessive clamping pressure will cause distortion. When clamping use some protective device on the vise, such as special soft jaws, pieces of hard rubber, or board.

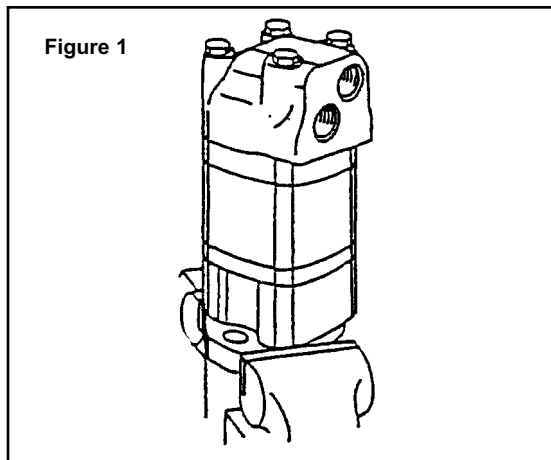

NOTE

Although not all drawings show the motor in a vise, we recommend that you keep the motor in the vise during disassembly and reassembly. Follow the clamping methods explained throughout the service procedures.

2. Remove the 4 Tie Bolts from the motor (Fig.2).

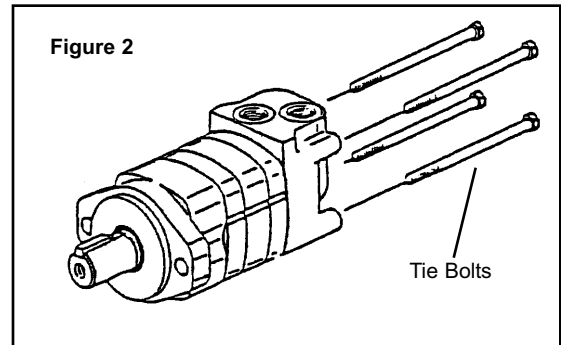

3. Lift Valve Housing straight up. If done carefully the Pins, Springs, Balance Ring Assembly, and Valve will remain on the Valve Plate (Fig. 3).

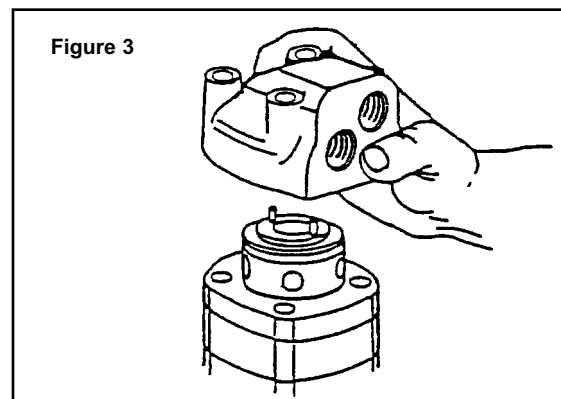

4. Carefully remove 3 [76] diameter seal from the Valve Housing (Fig. 4).
5. Remove case Drain Plug - with seal, from Valve Housing (Fig. 4).

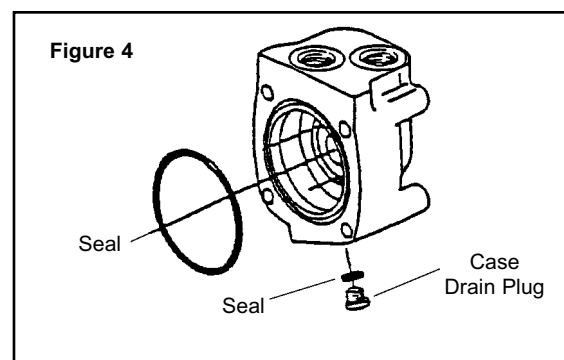

MOTOR SERVICE PROCEDURES DRIVE UNIT MODELS EA10, EA15, EA19

6. Remove 2 pins and 2 springs from Balance Ring Assembly (Fig. 5).
7. Remove Balance Ring Assembly (Fig. 5).
8. Remove inner and outer face seals from Balance Ring (Fig. 5).
9. Remove the Valve (Fig. 5).

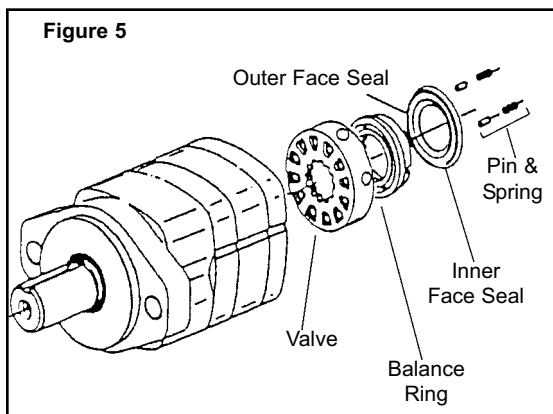

16. Remove the Shaft Face Seal from the Wear Plate.
14. Remove the 3 [76] dia. seal from Wear Plate (Fig. 8).
15. Remove the Wear Plate.
17. Remove the 3 [76] diameter seal from Bearing Housing (Fig. 8).

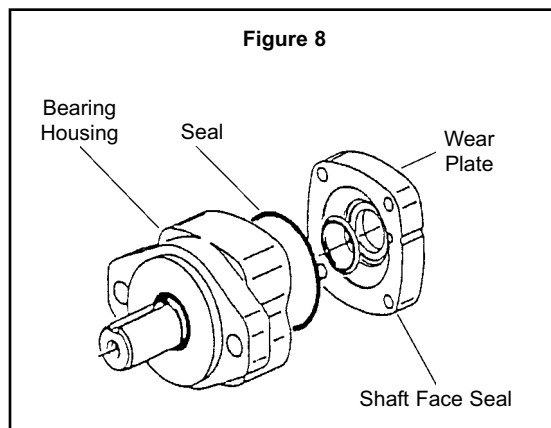

10. Remove the Valve Plate (Fig. 6).
11. Remove the 3 [76] dia. seal (Fig. 6).
12. Remove the Valve Drive.

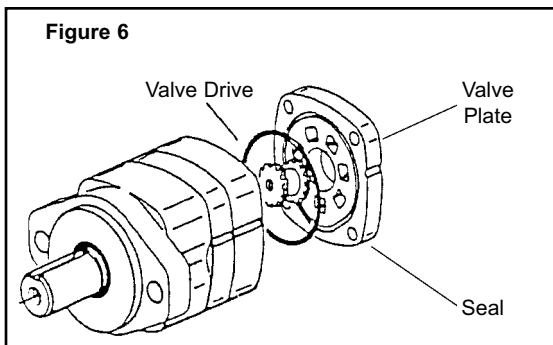

18. You may need a press to remove the Shaft and Bearing Assembly from the Bearing Housing (Fig. 9).

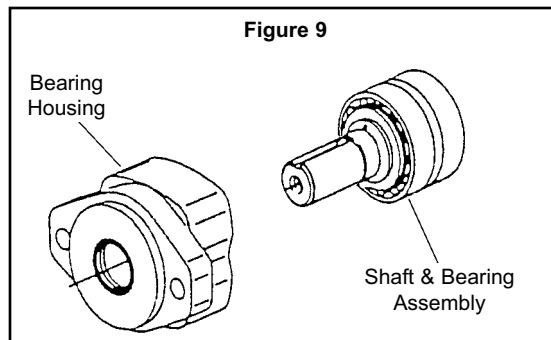

13. Remove the Geroler. Be sure to retain the rollers in the outer ring if they are loose. (Fig. 7).

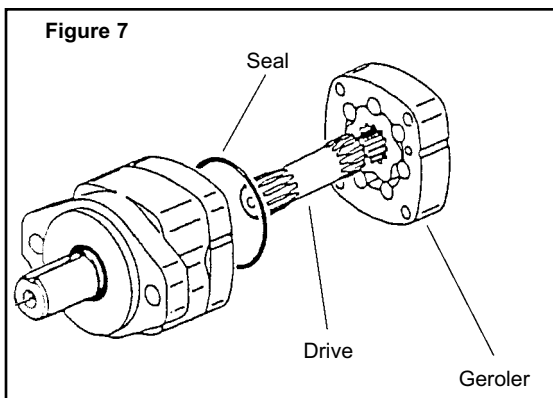

19. Use a small screwdriver to remove Shaft Seal, Back-up Washer and Dust Seal from Bearing Housing (Figure 10). **Do not damage bore of housing.**

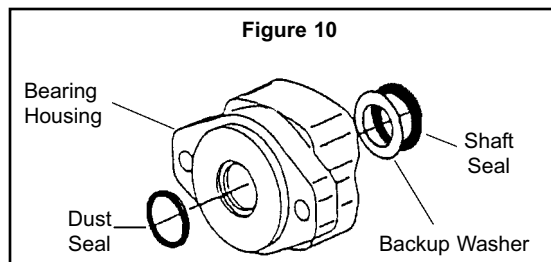

NOTE: Individual parts of shaft and bearing assembly are not sold separately. Replace as a unit.

MOTOR SERVICE PROCEDURES

DRIVE UNIT MODELS EA10, EA15, EA19

REASSEMBLY:

Check all mating surfaces. Replace any parts that have scratches or burrs that could cause leakage. Clean all metal parts in cleaning solvent. Blow dry with air. Do not wipe dry with cloth or paper towel because lint or other matter can get into the hydraulic system and cause damage. Do not use a coarse grit or try to file or grind these parts. Check around the keyway and chamfered area of the shaft for burrs, nicks or sharp edges that can damage the seals when reassembling the bearing housing.

NOTE: Lubricate all seals (prior to installation) with petroleum jelly such as Vaseline. Use new seals when reassembling this motor. Refer to parts list for proper seal kit number.

20. Use a press to install dust seal in outer bore of Bearing Housing. Lip of seal must face outward (Fig. 11). If a press is not available use a plastic or rubber hammer, being careful not to damage or cock seal in the bore.

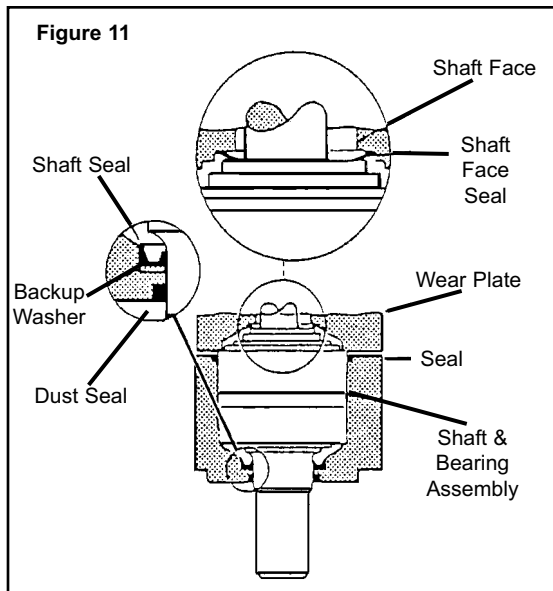

21. Place back-up washer into seal bore. Place shaft seal onto installation tool (#80-A3-300) and press seal onto seal bore of the housing.
22. Clamp housing on vise (see Fig. 1).
23. Place tape over shaft to prevent cutting the seals. Apply petroleum jelly to inside diameter of dust and shaft seal. You may need a press to install shaft and bearing assembly. Do not distort shaft seal. Damage to this seal will cause leakage.

24. Apply petroleum jelly to the 3 [76] diameter seal. Install seal into the bearing housing.
25. Alignment studs can be very helpful in reassembly of the motor (see special tools on page 22). If you use studs, install 2 studs diagonally opposed in the bearing housing.
26. Install the Shaft Face Seal in the Wear Plate as shown in Figure 11.
27. Install the Wear Plate (see Fig. 11).
28. Apply a light film of petroleum jelly to the 3 [76] diameter seal and install seal in the wear plate.
29. Install the drive in the bearing housing.
30. Align the notch on the outside of the Geroler with the notch on the wear plate. Install the Geroler against the wear plate. Be sure to retain the rollers in the outer ring if they are loose.

NOTE: Installation at this time involves 3 steps in the timing of the motor. Timing determines the direction of rotation of the output shaft. Timing parts include:

1. Geroler
2. Valve Drive
3. Valve Plate
4. Valve

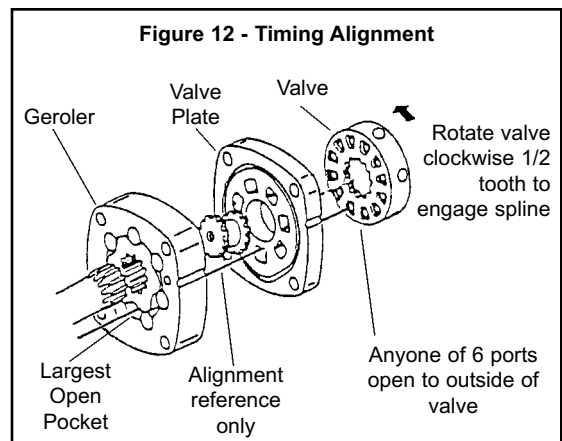

Timing Step#1: Locate the largest open pocket in the Geroler and mark it on the outside edge of the Geroler.

31. Install the valve drive in the Geroler.
32. Apply a light film of petroleum jelly to the 3 [76] diameter seal. Install seal in the groove of valve plate.
33. Align the notch on the outside of valve plate with the notch on the Geroler as shown in Figure 12.

MOTOR SERVICE PROCEDURES

DRIVE UNIT MODELS EA10, EA15, EA19

Timing Step#2: Locate the slot opening in the valve plate which is in line with the largest open pocket of the Geroler.

Timing Step#3: Locate any one of the side openings of the valve and align this opening with the open slot of the valve plate that is in line with the largest open pocket of the Geroler. Install the valve by rotating it clockwise until the spline teeth engage (1/2 spline tooth). This will provide the proper rotation when pressurized as shown in Fig. 13.

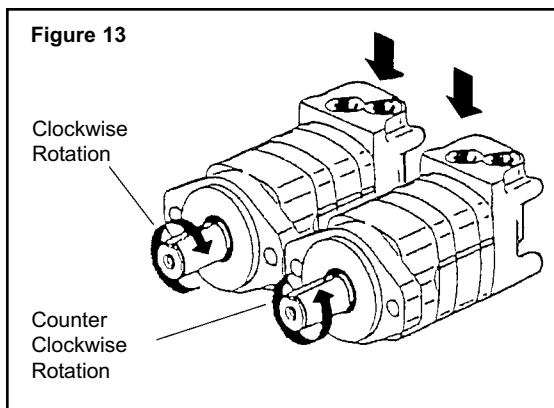

34. Install 2 springs and 2 pins in the holes located in the bore of the housing, as shown in Fig. 14.

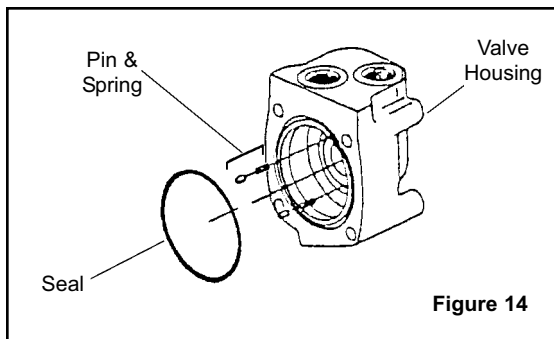

35. Apply a light film of petroleum jelly to the 3 [76] diameter seal. Install seal in the valve housing.

36. Apply petroleum jelly to inner and outer face seals. Install seals on balance ring as shown in Figure 15.

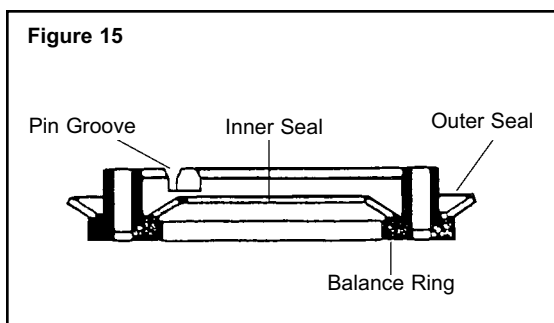

IMPORTANT: Install face seals in the positions shown in Figure 15 or the motor will not operate properly. Do not force or bend the face seals. Any damage to these seals will affect the operation of the motor.

37. Align pin grooves in balance ring with pins in bore of valve housing. Install balance ring assembly in valve housing.

38. Insert your finger through port of housing. Apply pressure to side of balance ring as shown in Fig. 16. Hold the ring in position until the valve housing is in place. Install valve against valve plate as shown in Figure 17.

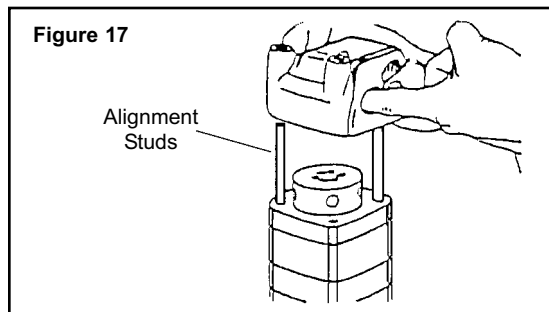
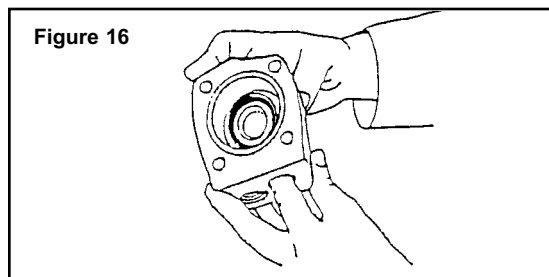

39. Install the tie bolts and finger tighten. Torque all four tie bolts alternately to 450 lb-in [50 nm].

40. Install seal on case drain plug then install in valve housing.

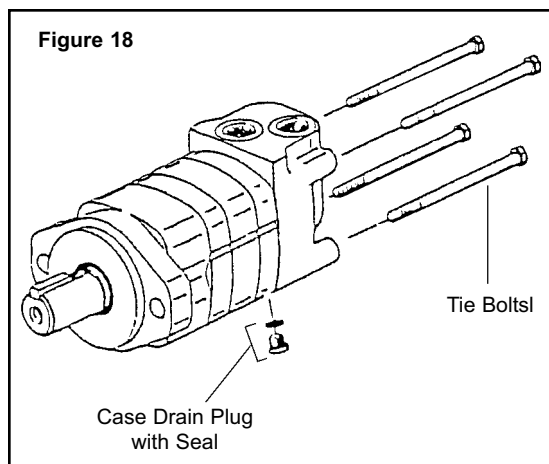

PLANETARY EXPLODED VIEW AND PARTS LIST DRIVE UNIT MODELS EA10, EA15, EA19

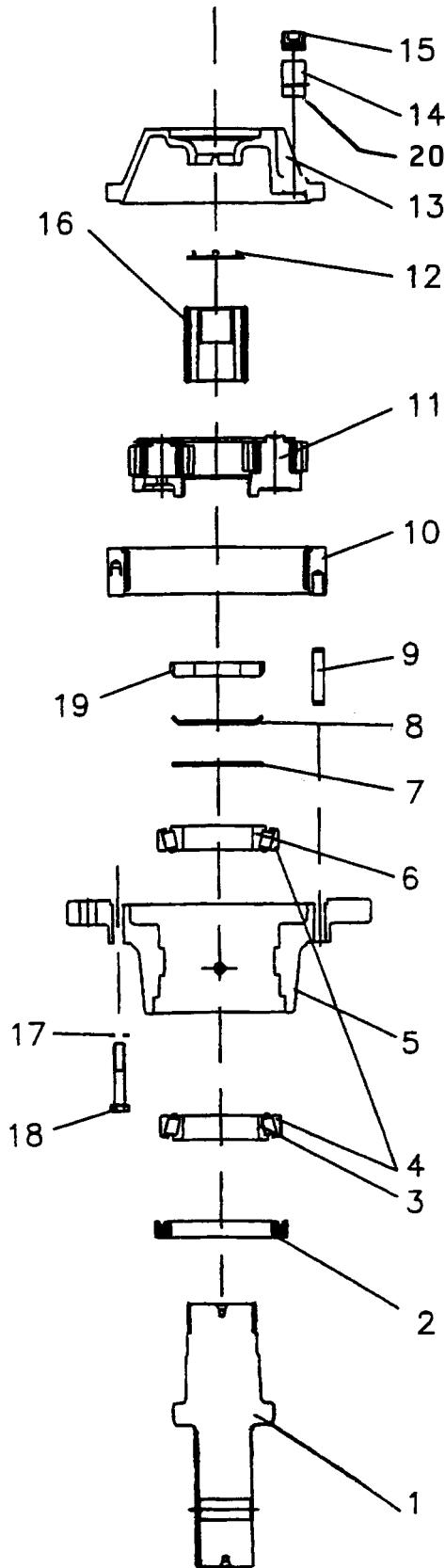

<u>Ref.#</u>	<u>Part #</u>	<u>Description</u>	<u>Qty.</u>
1694002" Hex Output Shaft.....	1
1694012-9/16" Round Output Shaft	1
269018Oil Seal	1
369403Outer Bearing Cone	1
469404Bearing Cup.....	2
569405Hub	1
669406Inner Bearing Cone	1
769407Thrust Washer	1
869408Lock Washer	1
969409Roll Pin	4
1069410Ring Gear	1
1169411Carrier Assembly	1
1269412Thrust Washer	1
1369413Cover	1
1461002Check Valve.....	1
1561003Breather Vent.....	1
1669414Sun Gear	1
1769415Flat Washer	6
1869416Bolt	6
1969417Shaft Lock Nut.....	1
2061045Breather Reducer Fitting	1

PLANETARY SERVICE PROCEDURES

DRIVE UNIT MODELS EA10, EA15, EA19

GENERAL INSTRUCTIONS:

To facilitate the repair of these units and before any work is done, we suggest that you first read all of the steps used in disassembly and assembly of unit.

It is important to air blast all parts and wipe them with clean, lint less cloth before assembly.

It is a good idea to check all replacement parts closely before installing to ensure that no damage occurred during shipment.

CAUTION - If parts are stubborn during assembly, do not force them and never employ an iron hammer.

Never hammer bearing cones or cups. Use only an arbor press or other suitable tool.

DISASSEMBLY:

1. Index mark all sections with a punch. Be sure to align all these marks when reassembling.
2. Remove bolts from cover. Lift cover from assembly. Thrust Washer usually remains with cover.
3. Lift Sun Gear from Carrier Assembly. Remove Carrier Assembly.
4. Remove 6 hex bolts and washers from hub. Pull Ring Gear from remaining assembly. It may be necessary to strike Ring Gear with a rubber mallet to loosen from hub.
5. **WARNING!** *Eye protection should be worn during retaining ring removal.* Remove Lock Nut from Output Shaft. Pull Output Shaft from Hub.
6. Remove Oil Seal and Bearing Cones from hub. Inspect Bearing Cups in hub and remove only if replacement is required.

ASSEMBLY:

1. Press new bearing cups into each side of hub. It is recommended that the bearing cups and Cones be replaced in sets.
2. Assemble bearing cone into cup at seal end of Hub.
3. Lubricate lips of oil seal and lower hub onto output shaft. Keep hub centered to prevent damage to oil seal.
4. **WARNING!** *Eye protection should be worn during retaining ring installation.* Assemble bearing cone over output shaft and into bearing cup. Install Thrust Washer, Lock Washer and Output Shaft Lock Nut above the Bearing. Bearings should have from .000 to .006 inches endplay when properly tightened.
5. Apply a bead of silicone sealant to face of hub that mates with Ring Gear.
6. Assemble Ring Gear to hub being careful to align all bolt holes.
7. Install six hex bolts and washers. Torque bolts to 52-60 ft/lbs.
8. Place carrier assembly into ring gear aligning the gear teeth. Carrier splines mesh with splines on output shaft. Place Sun Gear into Carrier Assembly. Sun Gear should turn freely by hand.
9. Apply a bead of silicone to cover face of Ring Gear.
10. Secure Thrust Washer with tangs engaged in cover. **Note:** Thrust Washer can be secured to cover with a small amount of grease or silicone sealant. Assemble cover to Ring Gear.
11. Install eight bolts and torque to 20-25 ft/lbs.
12. Position unit with output shaft pointing down and fill with oil (approximately 2 pints).

ACCESSORIES & AUGER REPLACEMENT WEAR PARTS

CONSTRUCTION AUGER TEETH

- Wisdom Tooth#00200
- Chisel Tooth#00201
- Wisdom Gage Tooth.....#00202
- Hardfaced Wisdom Tooth.....#00205
- Hardfaced Chisel Tooth#00206
- Hardfaced Wisdom Gage Tooth.....#00207
- Carbide Wisdom Tooth.....#00208
- Carbide Chisel Tooth#00209
- RB Carbide Wisdom Tooth.....#00237
- Tooth Pocket for CDC Augers#00225
- Rock Auger Bullet Tooth.....#00221
- Bullet Tooth Holder.....#00223
- 5/8"-11 Carriage Bolt 1-1/2" Long#40000
- 5/8"-11 Lock Nut.....#40001



Gage Tooth



Wisdom Tooth



Chisel Tooth



Rock Auger
Bullet Tooth

CONSTRUCTION AUGER PILOT POINTS

- Fishtail Point.....#00203
- Hardfaced Fishtail Point.....#00210
- Carbide Fishtail Point.....#00211
- 4-1/2" Auger Fishtail Point#00204
- Square Drive Lug#00105
- 4" Auger Drive Lug.....#00106
- CDR Rock Auger Pilot -
- with 1-3/4" Square Shank#00236
- with 2-3/8" API.....#00222
- CDR Rock Auger Bullet Tooth#00221
- CRB Rock Auger Fishtail Point#00239

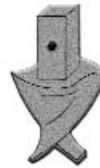

Fishtail Point



CRB Rock
Auger Fishtail
Point



CDR Rock
Auger Pilot

HOSES & FITTINGS

- Hydraulic Hoses 68" Long#61061
- Hydraulic Hoses 108" Long#61050
- Hydraulic Hoses 120" Long#61049
- Female Flat Faced Coupler#61006
- Male Flat Faced Coupler#61007
- Female Flat Faced Coupler#61010
- Male Flat Faced Coupler#61011

AUGER COLLARS

- 2" Hex Auger Collar#00102
- 2-9/16" Round Auger Collar.....#00101
- 2" Round Auger Collar#00100
- 2-1/2" Hex Collar#00103
- 2-5/8" Hex Collar#00104

MISCELLANEOUS WEAR PARTS

- Knuckle Pin#91001
- Drive Unit Housing.....#91000

